

Project Logic Diagrams

Executive Development Ltd © 2005

Project Logic Diagrams



One method of planning projects and identifying the critical path is to use "logic boxes" and project logic diagrams.

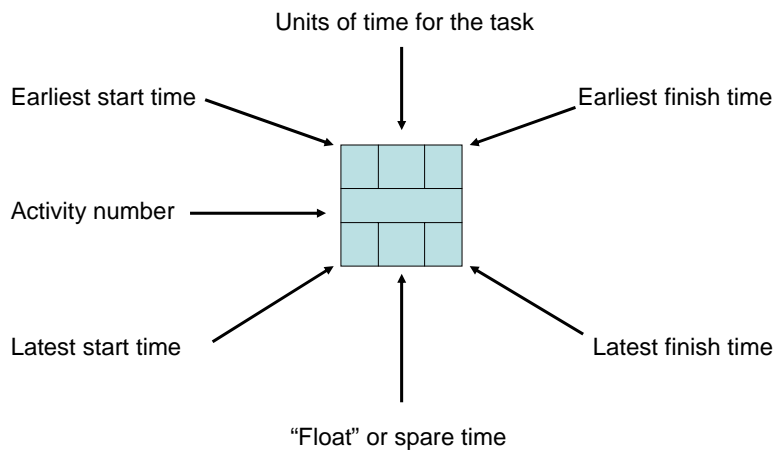

Executive Development Ltd © 2005

Project Logic Diagrams



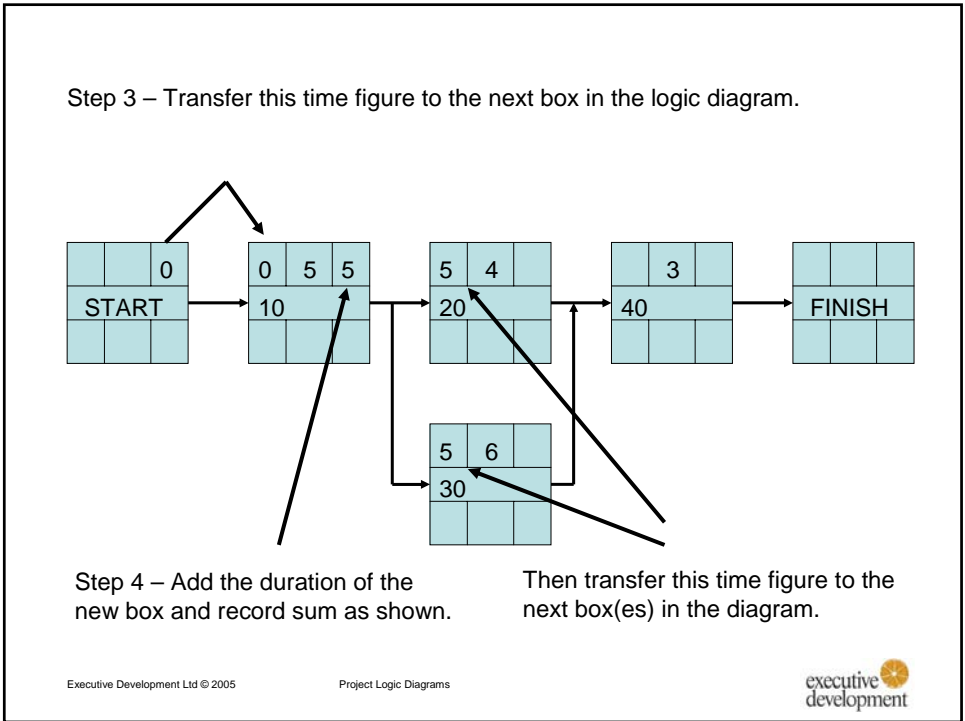
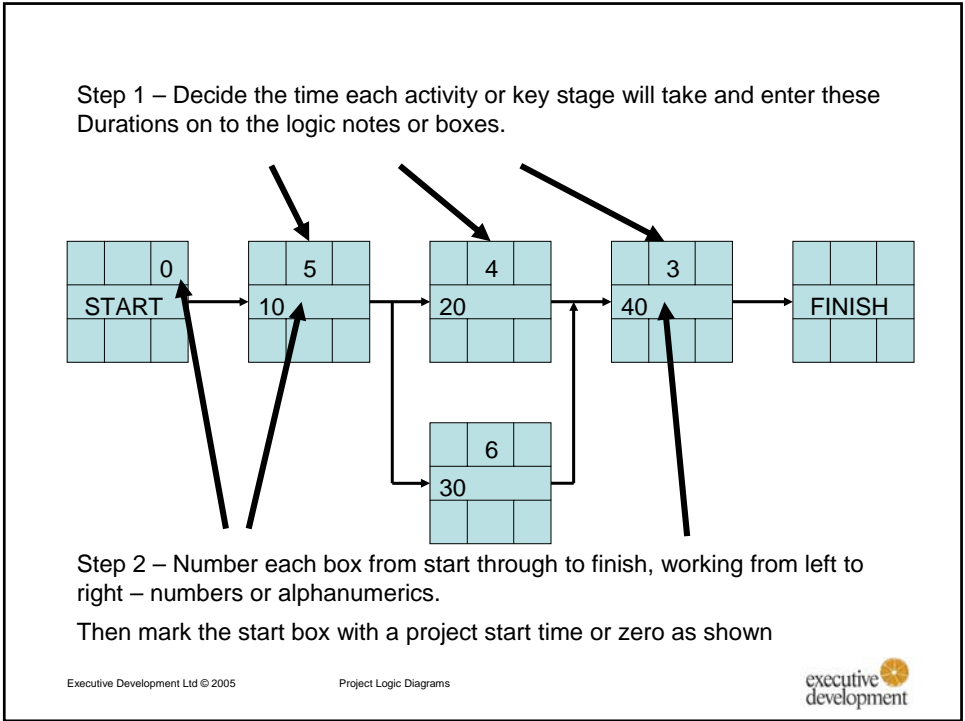

Step 5 – Repeat step 4, working through the logic diagram from left to right.

The completed forward pass analysis now looks like this:

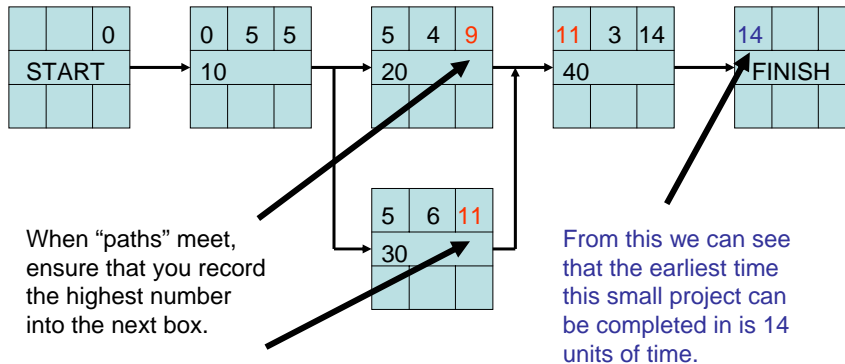

Executive Development Ltd © 2005

Project Logic Diagrams



Step 6 – The whole process is now reversed. Transfer the finish time to the Lower right-hand corner of the box as shown.

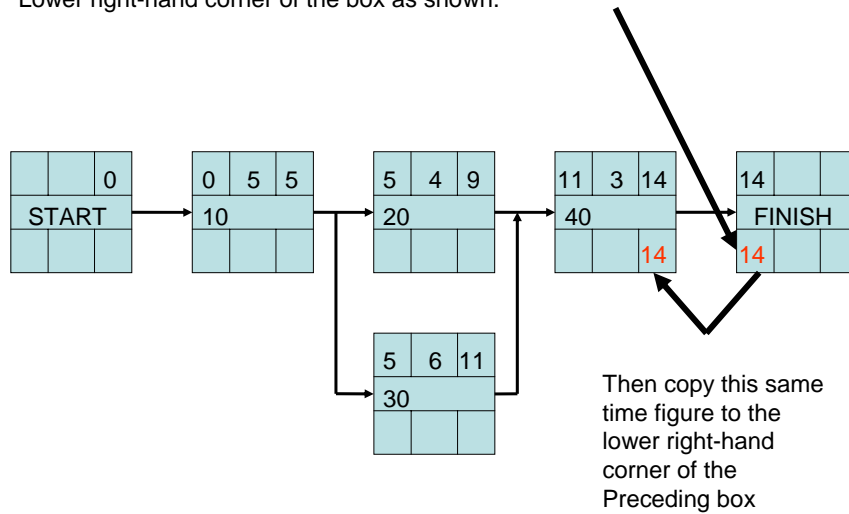

Executive Development Ltd © 2005

Project Logic Diagrams



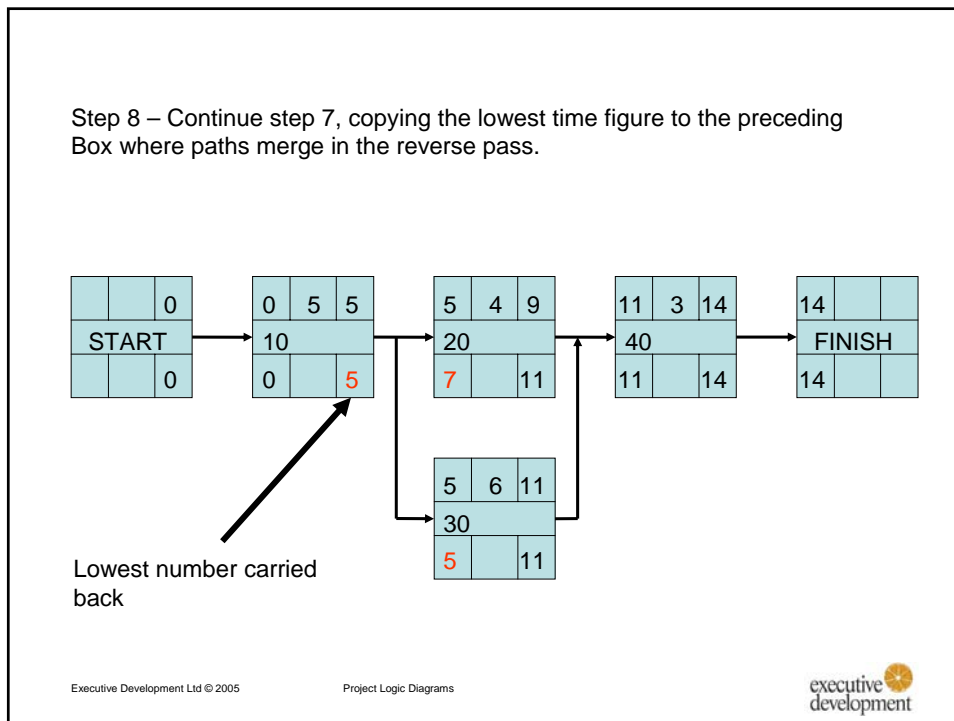
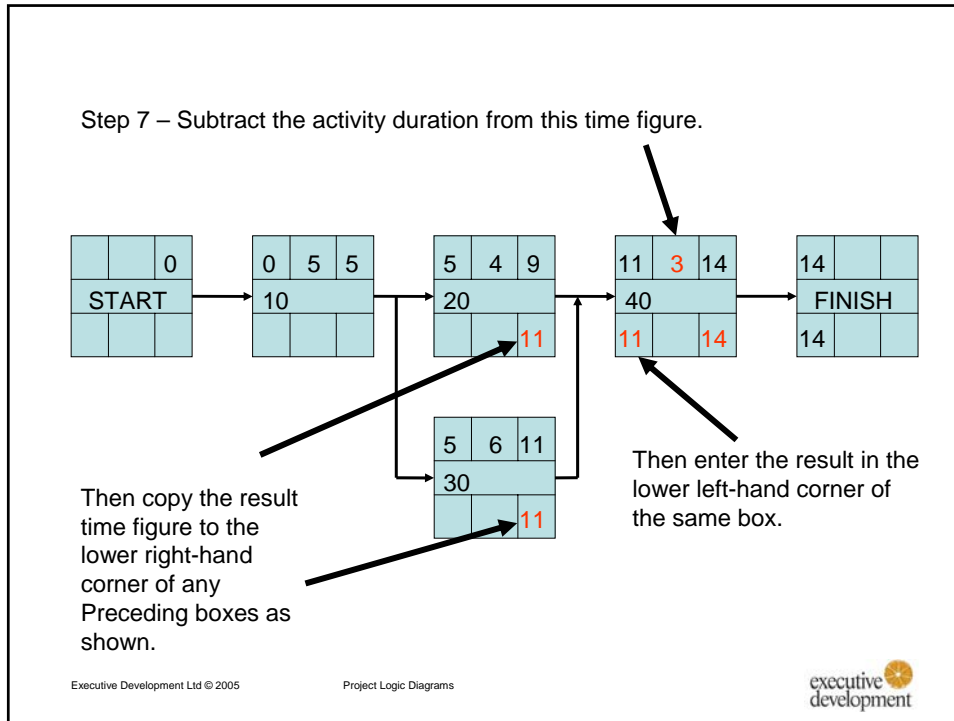

Step 9 – Calculate the “float” or spare time for each task.

Look at each box and record the difference between the figures in the upper and lower left-hand corners and the figures in the upper and lower right-hand corners, using the lower middle part of the box.

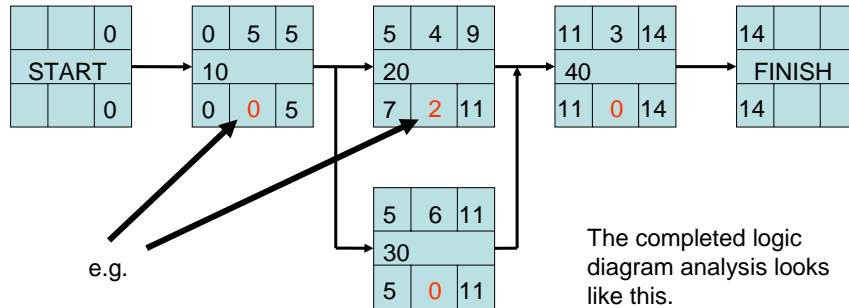

Each box now contains information about each activity or key stage of the Project.

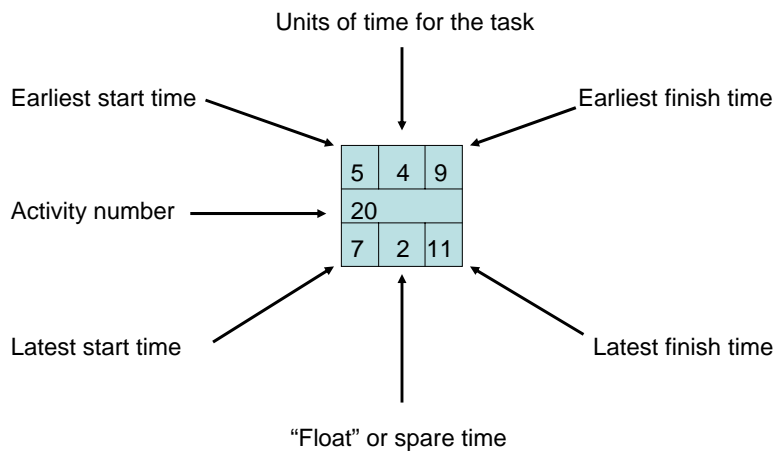

Step 10 – The Critical Path.

The activities that have zero float time form the critical path through the Project.

